

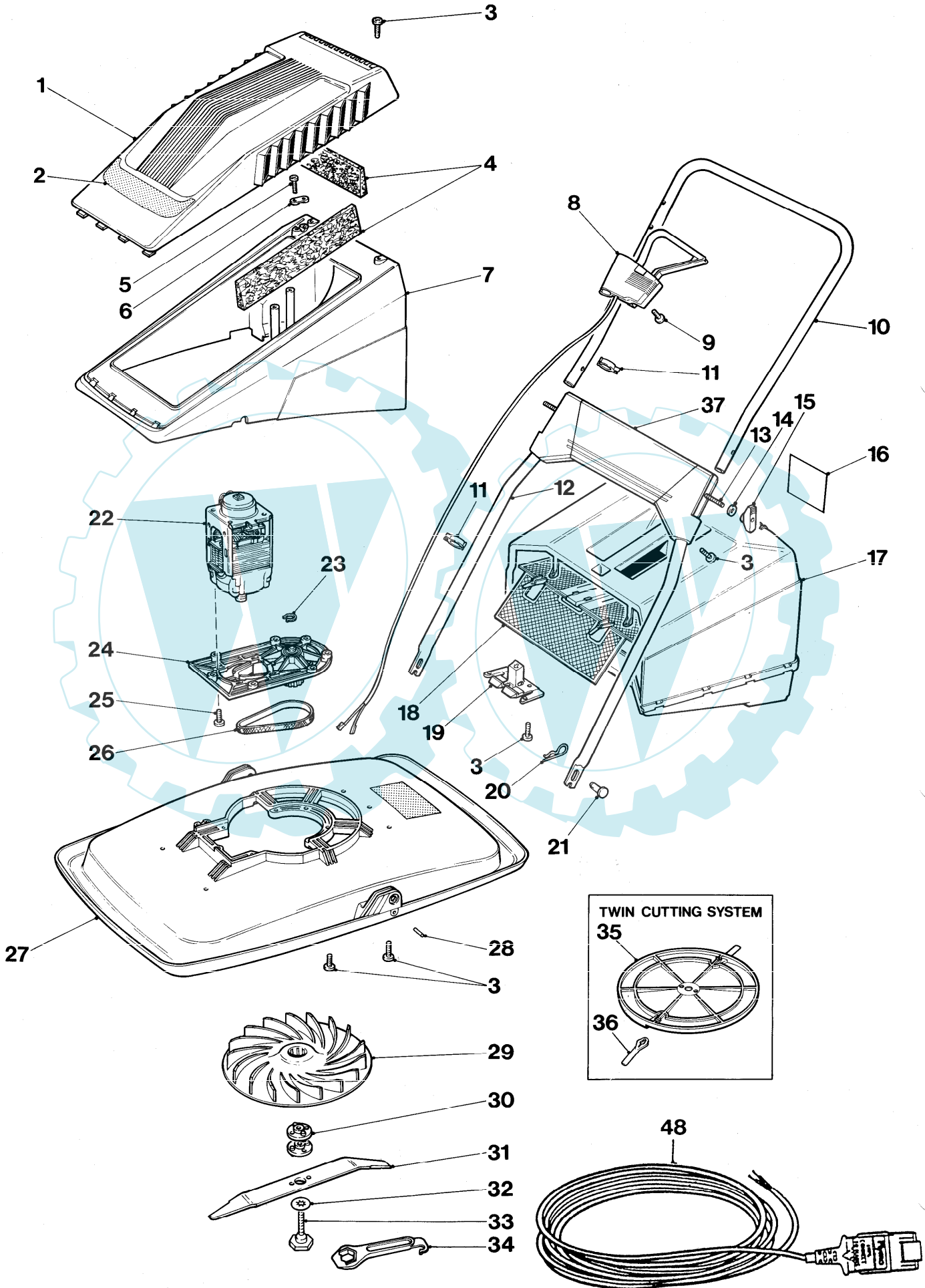

XE400 TWIN 9634001 SPRINTMASTER



Flymo®**XE400 TWIN 9634001
SPRINTMASTER**

KEY No	PART No	DESCRIPTION	QUANTITY	COMMENTS APPLICATION
1	5117343-00/3	COWL UPPER	1	
2	5126732-00/6	LABEL FLYMO	1	
3	5148649-01/4	SCREW PT 5 X 16	24	
4	5137846-00/1	FILTER	3	
5	5146941-00/9	SCREW HI-LO 04.32X16LG PAN	2	
6	5140705-00/4	CABLE CLAMP	1	
7	5106375-00/8	COWL LOWER	1	
8	5126891-10/9	SWITCHBOX ASSEMBLY	1	
9	5146672-00/0	SCREW NO 6 POZIDRIVE RECESSED	2	
10	5117402-00/7	HANDLE UPPER	1	
11	5137750-00/5	CLIP CABLE	2	
12	5117401-00/9	HANDLE LOWER	1	
13	5148736-00/1	BOLT HEX HEAD M6	2	
14	5140266-00/7	WASHER 6.4MM ID X 12MM OD	2	
15	5137679-00/6	WING KNOB M6	2	
16	5146467-00/5	LABEL WARNING	1	
17	51377966-00/7	GRASSBOX ASSEMBLY XE400	1	
18	5117299-00/7	GRASSBOX SCREEN	1	
19	5126989-00/2	GRASSBOX CLIP	1	
20	5140423-00/4	PIN RETAINING	2	
21	5140092-00/7	PIVOT PIN	2	
22	5126950-01/2	MOTOR 230/240V BRAKED	1	
23	5148648-00/8	CIRCLIP	1	
24	5137863-00/6	BASEPLATE/PULLEY ASSEMBLY	1	
25	5148696-01/5	MOTOR SCREW	1	
26	5137872-00/7	DRIVE BELT	1	
27	5137890-00/9	HOOD ASSEMBLY C.W PIN	1	
28	51475934-00/5	PIN	2	
29	5117227-01/6	IMPELLER	1	
30	5136668-01/8	BLADE SPACER PEGGED	1	
31	5126995-00/9	BLADE	1	
32	5148259-00/4	WASHER ANTI FRICTION PTFE	1	
33	5137608-00/5	BLADE BOLT C/W PTFE WASHER	1	
34	5126682-00/3	SPANNER/SCRAPER ABS	1	
35	5126735-00/9	DISC ASSY 38 CM	1	
36	5148257-02/4	CUTTER PLASTIC LONG LIFE	2	
37	5106435-00/0	CONSOLE XE400	1	
48	5126890-02/8	CABLE EXTENSION	1	

A Österreich, AUS Australia, B Belgique/Belgie, CND Canada, CH Schweiz/Suisse, D Deutschland, DK Danmark, E Espania, EI Eire, F France, GB Great Britain, I Italia, N Norge, NL Nederland, NZ New Zealand, O/S Overseas, P Portugal, S Sverige, SF Suomi, USA U.S.A., ZA South Africa

WHERE NO APPLICATION DETAILS ARE SHOWN, PART APPLIES TO ALL COUNTRIES

PRODUCT VARIANT
9634001-25 GB